



Twin-Lite™ Model 39 Magnified Linear Fluorescent Illuminator

Low Frequency (60 Hz)

FEATURES:

- Magnified, low distortion viewing
- High output, uniform and shadow-free illumination
- Flexible mounting options
- Hands-free, vibration-free positioning
- 7,000 hours of lamp life
- Wide range of lamp options available



StockerYale's Twin-Lite™ magnified linear fluorescent illuminator is an industrial and laboratory grade fluorescent lighting system that provides bright, shadow-free illumination for a variety of application needs including assembly and inspection.

The Twin-Lite magnified linear fluorescent illuminator incorporates a rugged linear lamp assembly with an adjustable swivel joint arm and a 2" x 4" (50.8mm x 101.6mm) lens that offers magnified viewing with low distortion. The Model 39 is designed for small, precise working areas with two 6" (152.4mm) long adjustable arms and a twin 4W linear lamp assembly.

The Twin-Lite is offered with either a rugged cast base or a sturdy clamp base to mount to a bench or tabletop. Both options offer easy, flexible positioning. Standard lamps are available in various white color temperatures, as well as wavelength specific colors including red, yellow, green, blue and black light blue (UV). Custom configurations may also be available.

Technical Specifications

Input power:	8 Watts
Input voltage (AC):	120 VAC or 220 VAC (50/60 Hz)
Operating frequency:	60 Hz
Lamp type:	(2) F4T5
Lamp output:	8 Watts
Color temperature:	4200K (cool white)*
Lamp life:	7,000 hours
Operating temperature:	32 to 104°F (0 to 40°C)
Humidity:	0 to 80%; non-condensing

Lamp Type:

13231	Description: White 4200K (cool white)*
13271	White 5100K (deluxe daylight)
13254	Black Light Blue, UV (365nm, peak)
13214	Blue (450nm, peak)
13224	Green (544nm, peak)
13304	Yellow (585nm, peak)
13294	Red (658nm, peak)

* Standard lamp provided

Dimensions

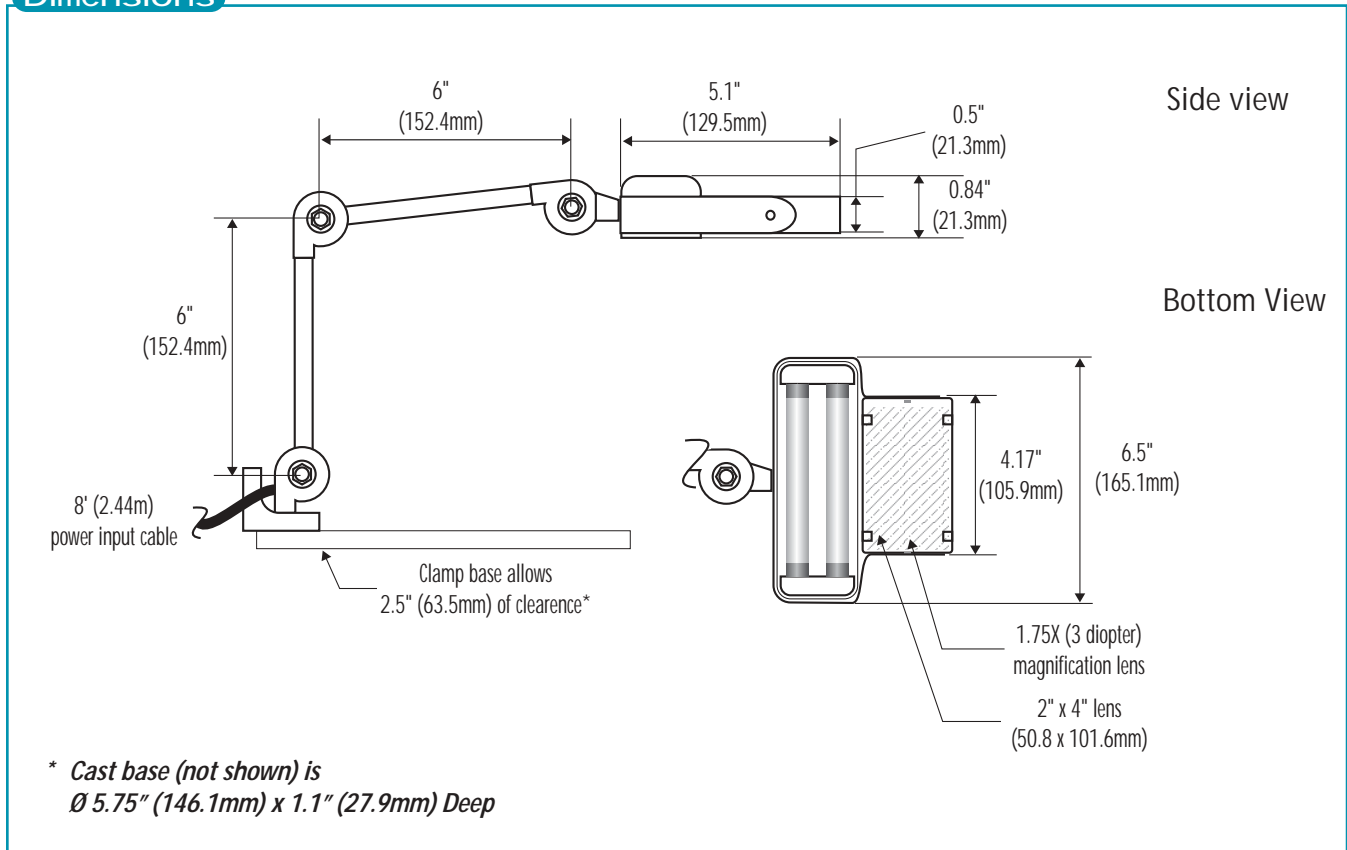

Corporate Headquarters
 32 Hampshire Road
 Salem, New Hampshire 03079 USA
800-843-8011
 603-893-8778 Fax: 603-893-5604
 sales@stockeryale.com
 www.stockeryale.com

StockerYale and the StockerYale logo are trademarks of StockerYale, Inc. All other brand and product names are trademarks or registered trademarks of their respective holders.

Copyright © August 2002 StockerYale, Inc. Printed in the USA
 All rights reserved. TK-003-01